

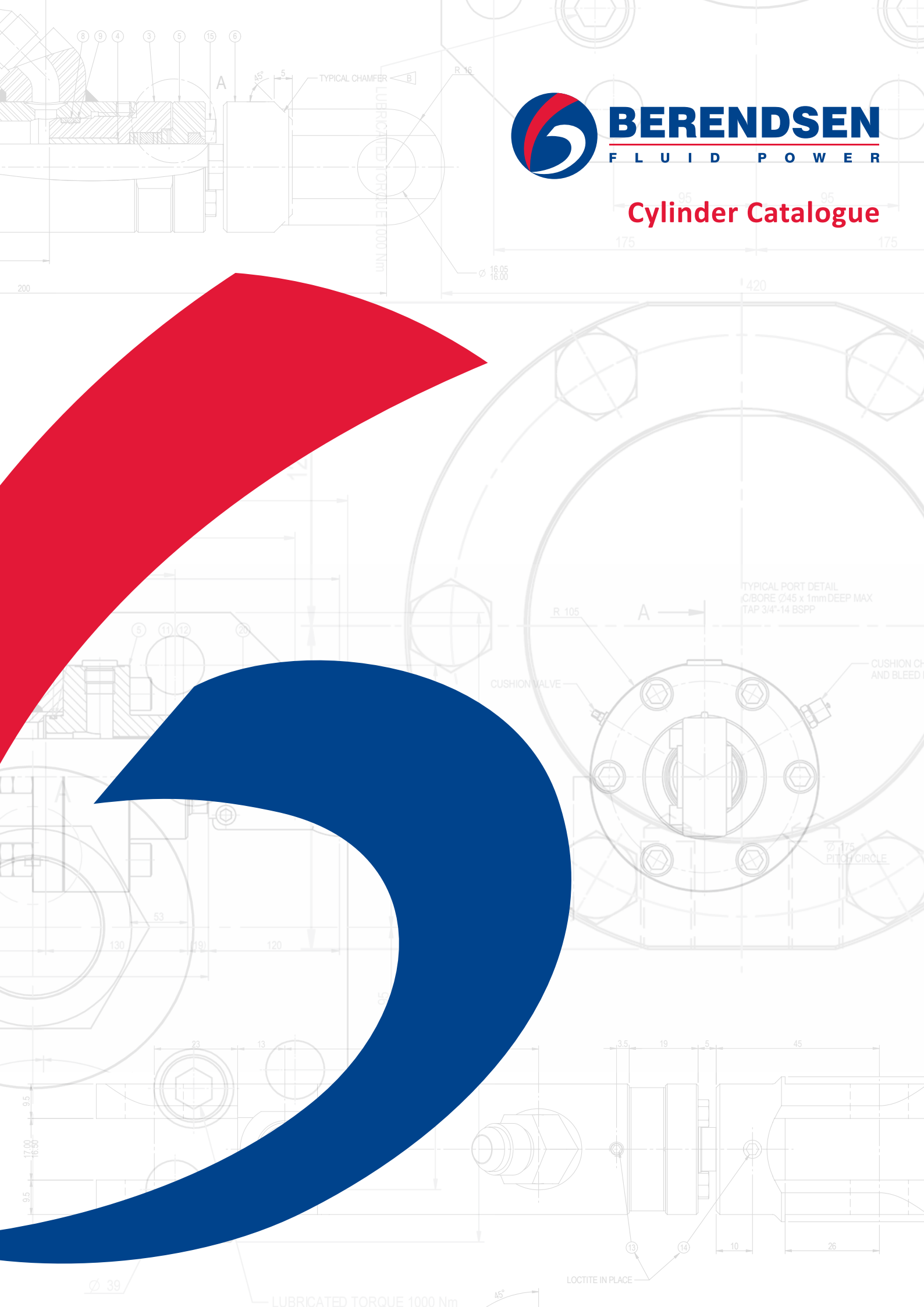

**BERENDSEN**  
FLUID POWER

# Cylinder Catalogue



TYPICAL CHAMFER

LUBRICATED TORQUE 1000 Nm

175 95 95 175

420

TYPICAL PORT DETAIL  
C/BORE  $\varnothing 45 \times 1 \text{mm DEEP MAX}$   
TAP 3/4"-14 BSPP

CUSHION VALVE

CUSHION CH  
AND BLEED

$\varnothing 175$   
PITCH CIRCLE

LOCTITE IN PLACE

LUBRICATED TORQUE 1000 Nm





## Table of Contents



	Page No.
About Berendsen Fluid Power & Our Products .....	1
About Our Cylinders.....	2
Medium Duty Roundline Cylinders .....	3
Heavy Duty Roundline Cylinders.....	5
AM1 Mill Cylinders .....	12
Custom Design Cylinders.....	19
Telescopic Cylinders .....	23
Technical Information.....	25



## About Berendsen Fluid Power Newcastle and Our Products

Berendsen Fluid Power is Australia's largest locally owned hydraulic company, consisting of 9 branches nationally.

Our Newcastle branch located at 10-18 Carbine Close, Wallsend, specialises in the design, manufacture and distribution of hydraulic and pneumatic cylinders for a wide range of applications. We are ISO 9001:2008 accredited and have a continual improvement process in place.

We have provided fluid power products, service and repair, system solutions and cylinder manufacture to the mining, manufacturing, marine, construction and viticulture industries to name a few, both locally and around Australia for over 25 years.

Our exposure to such a wide variety of industries has enabled us to develop highly regarded Roundline, Mill Style, Two Stage Load Hold, Telescopic and Special Purpose Cylinders.

### Features and Benefits of Berendsen Manufactured Cylinders:

- ✓ Australian made and owned
- ✓ Manufacturing cylinders since 1985
- ✓ Large cylinder range
- ✓ Continual research and development
- ✓ Branches Australia-wide providing local support
- ✓ Application engineering and re-engineering for optimum performance
- ✓ Compliance with ISO 9001:2008 standards

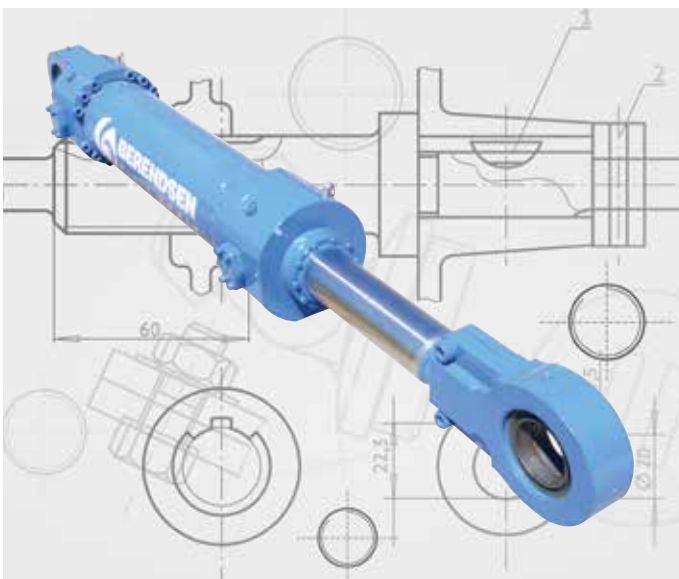

## About Our Cylinder

All of our manufactured cylinders are designed with the aid of computer generated calculations and drawings and are manufactured in our dedicated facility in Newcastle.

### Medium Duty Roundline (MDR)

The MDR version offers a variety of cylinder bore sizes from 4" to 8" diameter and have a working pressure of up to 210 Bar. Each cylinder size has the option of a standard or heavy duty rod and there is a variety of common mounts available to suit most applications.

### Heavy Duty Roundline (HDR)

The HDR cylinder bore sizes start from 40mm and go up to 200mm in our standard range with a 350 Bar peak pressure. Each HDR cylinder has the option of a standard or heavy duty rod and a number of mounting options available.

### AM1 Mill Cylinders

Our AM1 Series Mill Cylinder conforms to ISO 6022-1981 standards and are the first choice for a superiorly engineered heavy duty hydraulic cylinder. This product has an extensive 13 bore sizes in the range starting at 50mm up to 500mm which includes two non ISO sizes of 140mm and 180mm to supplement the range and bridge the gap between standard ISO sizes.

### Telescopic

Our telescopic cylinders are custom designed and manufactured to suit any application and to meet your desired stroke and closed centre distance requirements.

### Custom Design Cylinders

Berendsen Fluid Power custom designed and manufactured cylinders are available to suit any mobile and industrial application and to meet your desired specifications.



## Medium Duty Roundline Cylinders

Berendsen Fluid Power Roundline Cylinders are the first choice for a well engineered, medium duty hydraulic cylinder for the diverse mobile and industrial applications. Designed with the aid of computer generated calculations and drawings, the cylinders are manufactured in our dedicated manufacturing facility in Newcastle.

### Key Features:

- Bore sizes available 4", 4.5", 5", 6", 7" and 8" with two rod sizes available with each bore size.
- Customer specified stroke lengths available from 10 mm to 1300 mm. Longer strokes are available, however, subject to individual design.
- Cylinders designed to operate at 210 Bar nominal and 250 Bar peak. Safety factor of 3:1 on yield at 210 Bar nominal pressure.
- Designed to provide a compact and economical design.
- The cylinder barrel is manufactured from high strength grade SAE 1026 DOM tube. The bore is precision honed and polished to a 0.4 micron finish.
- The cylinder end cap and rear mounting clevis are welded to the Australian Standard AS4041 "Pressure Pipe Welding Code". This ensures full adherence to qualified procedures and post weld ultrasonic examination.
- The piston rods are machined from high strength carbon steel and hard chrome plates and ground to a 0.2 micron finish.
- A threaded gland facilitates assembly and disassembly and is torqued to preset limits. It houses a medium duty rod wiper to protect against contaminant ingress. It also houses a single acting rod seal and provides an extended bearing surface for longer life.
- The piston is tightened to a preset torque and scotch keyed for additional security. It houses a double acting piston seal with integral non metallic wear rings to prevent metal to metal contact.
- A range of rod end clevises is offered which includes spherical bearing options as well as male and female plain clevises.
- A wide range of Load Holding valve options are available including externally mounted block or the option of having cartridge valves built into the endcap to reduce the possibility of damage. No increase to cylinder closed length (ie. 'x + stroke' dimension) with endcap built-in valve option.
- Standard ports are BSPP with machined spot face for face sealed fittings.

	Description	Code	Example
<b>Series</b>	Used in all MDR Series	MDR	MDR - 6.0 - MP7 - 3.5 - 250 - FC - BSP/A - S
<b>Bore Dia</b>	Specify in Inches		
<b>Mounting Type</b>	Cap Fixed Eye Male	MP3	
	Cap Fixed Spherical	MP5	
	Cap Fixed Female	MP7	
<b>Rod Dia</b>	Specify Diameter in Inches		
<b>Stroke</b>	Specify in millimetres. If stroke is over 1300 mm consult Berendsen Fluid Power.		
<b>Accessories Rod Ends</b>	Swivel Clevis	SC	
	Male Clevis	MC	
	Female Clevis	FC	
	(Omit if not required)		
<b>Port Options</b>	Port Type - BSPP	BSP	
	Port Type - Other	OTHER	
	Port Position - 90 degrees to Pin	A	
	Port Position - In Line with Pin	B	
<b>Special Features</b>	Viton Seals	S1	
	4140 Rod	S2	
	Dual Load Holding - Inbuilt	S3	
	Dual Load Holding - External	S4	
	Other	S5	
	Specify details or provide drawing (Omit if not required)		

- **Standard operating limits**  
Fluid: Hydraulic mineral oil  
Viscosity: 2.8 to 380cST  
Oil Temperature: -30° to 90°  
Operating Speed: 300mm/sec. maximum
- **Non-standard cylinders**  
Any cylinder configurations outside of those detailed in this catalogue are subject to individual design and quotation.
- **Note\***  
Specify any non-standard dimension at end of code.  
Example: MDR-6.0-MP7-3.5-250-FC-BSP/A-S (CC=150mm)

## Medium Duty Roundline Cylinders cont.

### GA & Clevis Mount

BORE (in.)	ROD (in.)	B (BSPP Port)	C	ØD (Max)	ØE (Thread)	F	G	H + Stroke	J	K	A/F	X+ Stroke	CA	CB	CC	CD	CE	CF	CG	CH	CI	CJ	CK	CL	CM	CN	CO	CP	CQ	CR	CS	CT	SPHERICAL BEARING
4.0	2.0	1/2	20	114.3	1.75" UNF	40	28	85	65	19	44	197	31.75	45	95	105	45	55	20	25	40	44	50	36	80	80	55	40	40	56	35	40	GE45DO-2RS
	1.75" UNF				40	52																											
4.5	2.0	1/2	20	133.35	1.75" UNF	40	28	92	66	22	44	208	31.75	45	95	105	50	55	25	25	44	44	55	36	80	80	55	40	40	56	40	40	GE45DO-2RS
	1.75" UNF				40	52																											
5.0	2.25	3/4	25	146.05	2.0" UNF	40	28	98	72	25	52	223	38.1	50	95	120	55	60	28	28	44	44	60	40	90	95	55	44	44	60	44	44	GE50DO-2RS
	2.0" UNF				40	56																											
6.0	3.0	1	25	171.45	2.5" UNF	50	30	112	92	33	68	267	50.8	60	130	140	66	75	32	32	65	65	65	48	100	105	80	58	58	72	58	58	GE60DO-2RS
	2.5" UNF				50	80																											
7.0	3.5	1 1/4	25	203.2	3" UNF	60	34	132	98	33	80	297	60	70	155	165	80	90	35	35	70	70	70	54	115	120	95	65	65	88	65	65	GE70DO-2RS
	3" UNF				60	90																											
8.0	4.0	1 1/4	25	228.6	3.25" UNF	70	34	148	114	37	90	333	70	80	180	190	95	110	38	38	75	75	80	60	130	135	110	72	72	100	72	72	GE80DO-2RS
	3.25" UNF				70	104																											

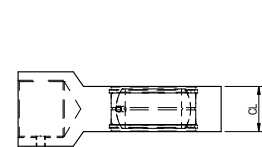
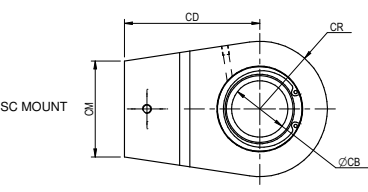
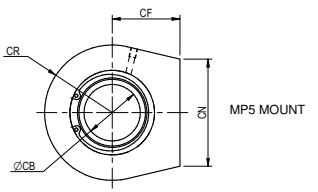
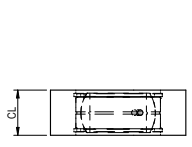
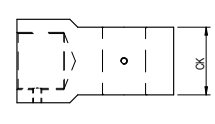
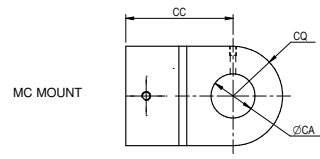
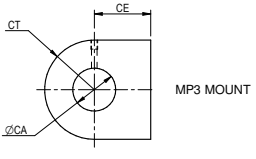
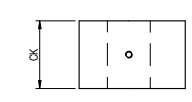
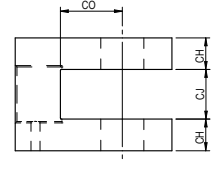
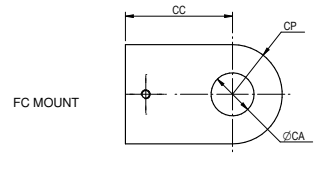
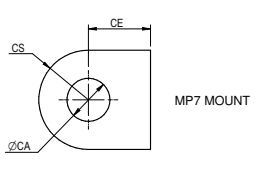
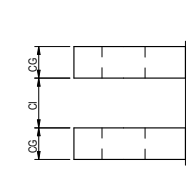
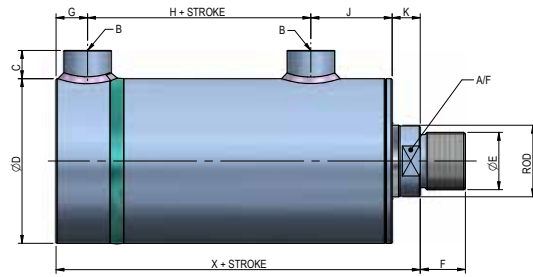



## Heavy Duty Roundline Cylinders

Berendsen Fluid Power Roundline Cylinders are the first choice for a well engineered, heavy duty hydraulic cylinder for the diverse mobile and industrial applications. Designed with the aid of computer generated calculations and drawings, the cylinders are manufactured in our dedicated manufacturing facility in Newcastle.

### Key Features:

- Designed to ISO 6020/1-1981 international Standards for mounting dimensions. Maintained all critical mounting dimensions to provide commonality between cylinders. However, the standard range featured in this catalogue are shorter in overall length than the standard in order to have a more compact and economical design. Please note that we are able to offer a cylinder fully conforming to the standard upon request.
- The cylinders are designed to operate at 250 Bar nominal, 350 Bar peak pressures with the exception of MF1 and MF2 mounts. Please refer to the pressure limitation table for these latter two mounts.
- The cylinder barrel is manufactured from high strength grade SAE 1026 DOM tube. The bore is precision honed and polished to a 0.4 micron finish.
- The cylinder end cap and mounting Trunnion or clevis are welded to the Australian Standard AS4041 "Pressure Pipe Welding Code" with full adherence to qualified procedures and post weld ultrasonic examination.
- The piston rods are machined from high strength carbon steel and hard chrome plates and ground to a 0.2 micron finish.
- A threaded gland facilitates assembly and disassembly and is torqued to preset limits. It houses a heavy duty rod wiper to protect against contaminant ingress. It also houses a single acting rod seal and provides an extended bearing surface for longer life.
- The piston is tightened to a preset torque and scotch keyed for additional security. It houses a double acting piston seal with integral non metallic wear rings to prevent metal to metal contact.
- All cylinders are available upon request with progressive, fixed cushioning at either end complete with fast return check valves.
- A full range of rod end clevises is offered which includes spherical bearing options as well as male and female plain clevises.
- Standard ports are BSPP with machined spot faces for face sealed fittings.

	Description	Code	Example
Series	Used in all HDR Series	HDR	HDR - 50 - MP3 - 36 - 250 - MC - S
Bore Dia	Specify in millimetres		
Mounting Type	Head Rectangular Flange	MF1	
	Cap Rectangular Flange	MF2	
	Head Circular Flange	MF3	
	Cap Circular Flange	MF4	
	Cap Fixed Eye	MP3	
	Cap Fixed Spherical	MP5	
	Cap Fixed Female	MP7	
	Head Trunnion	MT1	
	Cap Trunnion	MT2	
	Intermediate Trunnion	MT4*	
	Foot Mount	FM1	
Rod	Specify Diameter (mm)		
Stroke	Specify in millimetres. If stroke is over 20 times cylinder bore, consult Berendsen Fluid Power.		
Accessories Rod Ends	Swivel Clevis	SC	
	Male Clevis	MC	
	Female Clevis	FC	
	(Omit if not required)		
Special Features	Specify with order or provide drawing	S	
	(Omit if not required)		

- **Standard operating limits**  
Fluid: Hydraulic mineral oil  
Viscosity: 2.8 to 380cST  
Oil Temperature: -30° to 90°  
Operating Speed: 50 mm/sec. maximum
- **Non-standard cylinders**  
Any cylinder configurations outside of those detailed in this catalogue are subject to individual design and quotation.
- **Note\***  
Specify any non-standard dimension at end of code for MT4 Mount.  
Example: HDR-50-MT4-36-250-MC-S (XV=600mm)

Heavy Duty Roundline Cylinders cont.

HDR Clevis Mount - MP3 / MP5 / MP7

BORE mm	MM ROD	KK THREAD	A	PP BSPP PORT	WV	ΦE MAX	P (+str)	PA	X (+str)	L	M	ΦCD, ΦCX	EW, EX	EA	EB	MM
40	22	M16 X 1.5	22	3/8	13	55	63.5	40	164	30	25	20	20	8	15	35
	28	M20 X 1.5	28													
50	28	M20 X 1.5	28	3/8	14	65	68.5	45	180	35	30	25	25	10	20	40
	36	M27 X 2	36													
63	36	M27 X 2	36	1/2	16	75	70	67	214	45	37	32	32	12	25	55
	45	M33 X 2	45													
80	45	M33 X 2	45	1/2	18	95	78	77	246	55	45	40	40	16	30	65
	56	M42 X 2	56													
100	56	M42 X 2	56	3/4	20	125	100	98	309	65	56	50	50	20	40	80
	70	M48 X 2	63													
125	70	M48 X 2	63	1	23	150	116	138	366	80	68	63	63	25	50	95
	90	M64 X 3	85													
160	90	M64 X 3	85	1 1/4	25	195	143	142	447	95	85	80	80	32	65	120
	110	M80 X 3	95													
200	110	M80 X 3	95	1 1/2	30	245	160.5	139.5	492	120	110	100	100	40	80	147
	140	M100 X 3	112													

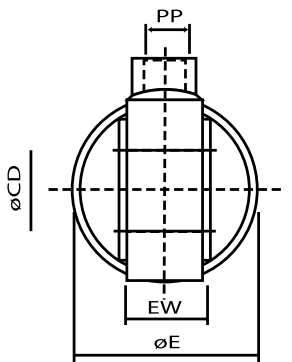
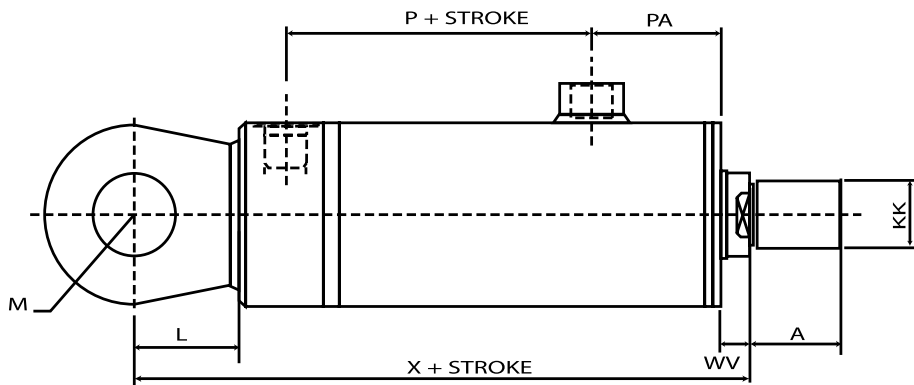

MP3  
CAP FIXED  
EYE MOUNTING

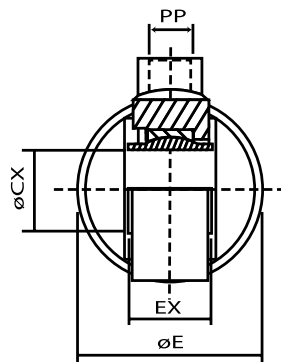

MP5  
CAP FIXED  
SPHERICAL  
BEARING MOUNTING

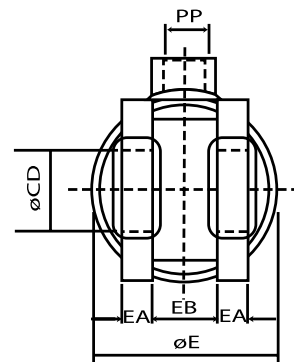

MP7  
CAP FIXED  
FEMALE CLEVIS  
MOUNTING



## Heavy Duty Roundline Cylinders cont.

### HDR Trunion Mount - MT1 / MT4

BORE mm	mm ROD	KK THREAD	A	PP BSPP PORT	WV	ΦE MAX	P (+str)	PA	ZB (+str)	ZC	ZA (+str)	XG	XJ (+str)	XV (+0.5 str)	UL	UD	ΦTD	U	TL	T
40	22	M16 X 1.5	22	3/8	13	55	63.5	40	136	136	136	25.5	116.5	68.5	25	28	20	66	16	90
	28	M20 X 1.5	28																	
50	28	M20 X 1.5	28	3/8	14	65	68.5	45	147	147	147	29	127.5	73.5	30	32	25	80	20	105
	36	M27 X 2	36																	
63	36	M27 X 2	36	1/2	16	75	70	67	171	171	174	40	154	86.5	40	40	32	99	25	120
	45	M33 X 2	45																	
80	45	M33 X 2	45	1/2	18	95	78	77	193	198	203	47	178	96.5	5	50	40	124	32	135
	56	M42 X 2	56																	
100	56	M42 X 2	56	3/4	20	125	100	98	246	256	261	57.5	228	128	65	65	50	148	40	160
	70	M48 X 2	63																	
125	70	M48 X 2	63	1	23	150	116	138	288	313	268	68	257	157	80	80	63	177	50	195
	90	M64 X 3	85																	
160	90	M64 X 3	85	1 1/4	25	195	143	142	354	389	369	80	317	203	100	100	80	221	63	240
	110	M80 X 3	95																	
200	110	M80 X 3	95	1 1/2	30	245	160.5	139.5	374	374	419	100	354	225	130	120	100	270	80	295
	140	M100 X 3	112																	

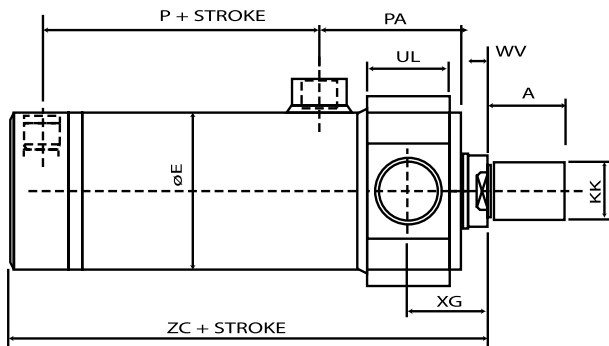

MT1 - HEAD TRUNNION

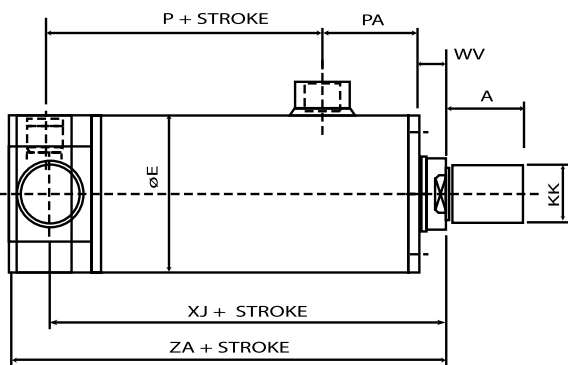
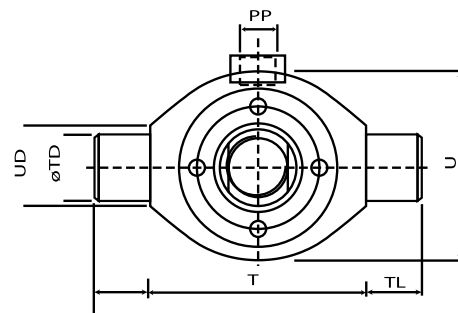

MT1 - CAP TRUNNION

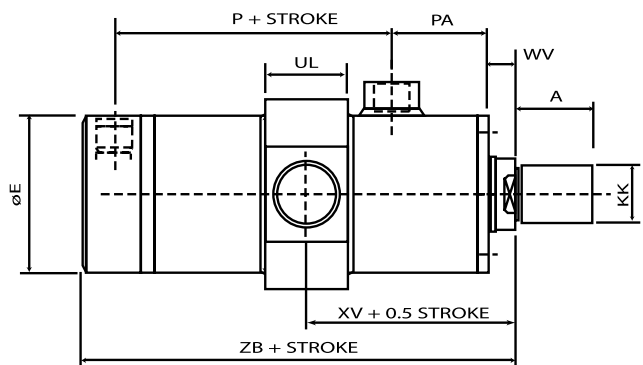

MT4 - INTERMEDIATE TRUNNION

Heavy Duty Roundline Cylinders cont.

HDR Rectangular Flange Mount - MF1 / MF2

BORE mm	MM ROD	KK THREAD	A	PP BSPP PORT	VD	ΦB	WC, W	WV	ΦE MAX	P (+str)	PA	ZB (+str)	ZP, ZF (+str)	F	ΦFB	FC	UC	TF	R	UF	UR
40	22	M16 X 1.5	22	3/8	3	50	16	13	55	63.5	40	136	150	16	9	106	125	98	40.5	116	60
	28	M20 X 1.5	28																		
50	28	M20 X 1.5	28	3/8	4	60	18	14	65	68.5	45	147	165	20	11	126	150	116.4	48.2	140	72
	36	M27 X 2	36																		
63	36	M27 X 2	36	1/2	4	70	20	16	75	70	67	171	194	25	13.5	145	175	134	55.5	165	90
	45	M33 X 2	45																		
80	45	M33 X 2	45	1/2	4	85	22	18	95	78	77	193	223	32	17.5	165	200	152.5	63.1	190	110
	56	M42 X 2	56																		
100	56	M42 X 2	56	3/4	5	106	25	20	125	100	98	246	276	32	22	200	245	184.8	76.5	235	130
	70	M48 X 2	63																		
125	70	M48 X 2	63	1	5	132	28	23	150	116	138	288	318	32	22	235	280	217.1	90.2	270	170
	90	M64 X 3	85																		
160	90	M64 X 3	85	1 1/4	5	160	30	25	195	143	142	354	386	36	22	280	325	295	125	360	214
	110	M80 X 3	95																		
200	110	M80 X 3	95	1 1/2	5	200	35	30	245	160.5	139.5	374	412	40	26	340	395	370	155	455	270
	140	M100 X 3	112																		

BORE SIZE (mm)	MAX. PREASURE (BAR)		
	EXTEND	RETRACT	
		STD	HD
40	150	250	250
50	150	250	250
63	200	250	250
80	250	250	250
100	150	250	250
125	125	175	250
160	75	100	150
200	50	75	100

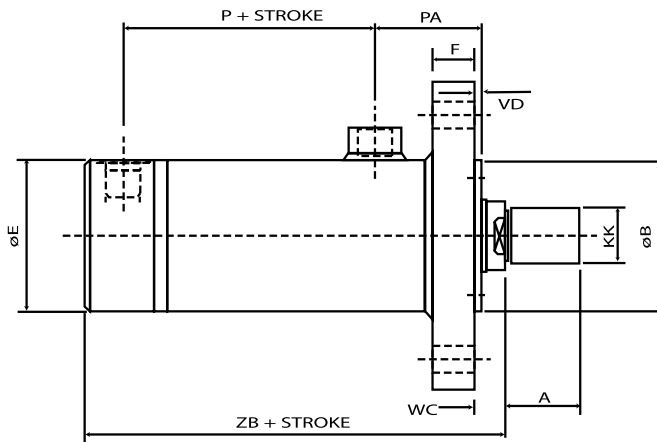

MF1 - HEAD RECTANGULAR FLANGE

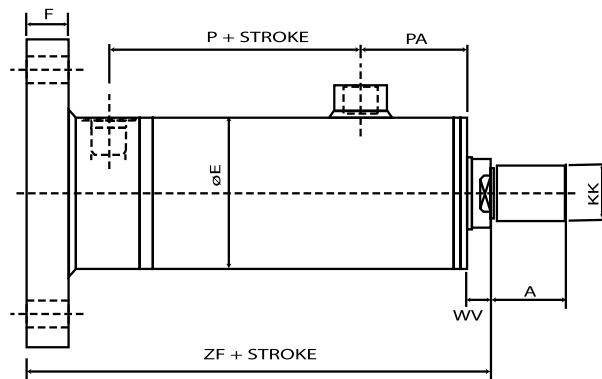
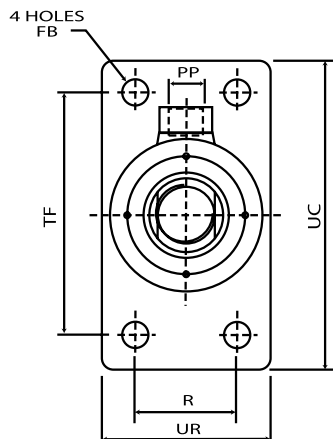

MF2 - CAP RECTANGULAR FLANGE



## Heavy Duty Roundline Cylinders cont.

### HDR Circular Flange Mounted - MF3 / MF4

BORE mm	MM ROD	KK THREAD	A	PP BSPP PORT	VD	ΦB	WC, W	WV	ΦE MAX	P (+str)	PA	ZB (+str)	ZP, ZF (+str)	F	ΦFB	FC	UC
40	22	M16 X 1.5	22	3/8	3	50	16	13	55	63.5	40	136	150	16	9	106	125
	28	M20 X 1.5	28														
50	28	M20 X 1.5	28	3/8	4	60	18	14	65	68.5	45	147	165	20	11	126	150
	36	M27 X 2	36														
63	36	M27 X 2	36	1/2	4	70	20	16	75	70	67	171	194	25	13.5	145	175
	45	M33 X 2	45														
80	45	M33 X 2	45	1/2	4	85	22	18	95	78	77	193	223	32	17.5	165	200
	56	M42 X 2	56														
100	56	M42 X 2	56	3/4	5	106	25	20	125	100	98	246	276	32	22	200	245
	70	M48 X 2	63														
125	70	M48 X 2	63	1	5	132	28	23	150	116	138	288	318	32	22	235	280
	90	M64 X 3	85														
160	90	M64 X 3	85	1 1/4	5	160	30	25	195	143	142	354	386	36	22	280	325
	110	M80 X 3	95														
200	110	M80 X 3	95	1 1/2	5	200	35	30	245	160.5	139.5	374	412	40	26	340	395
	140	M100 X 3	112														

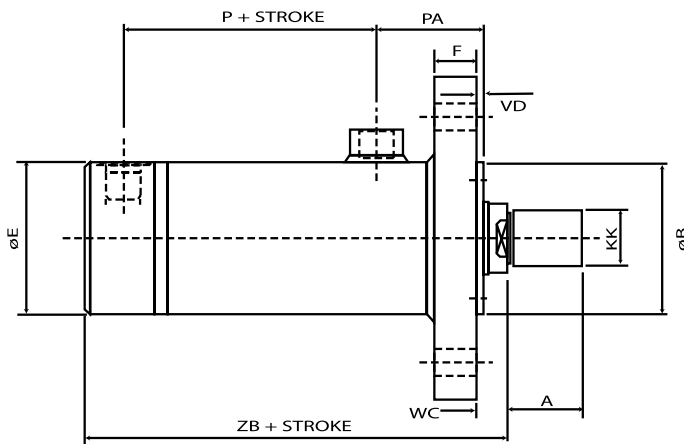

MF3 - HEAD CIRCULAR FLANGE

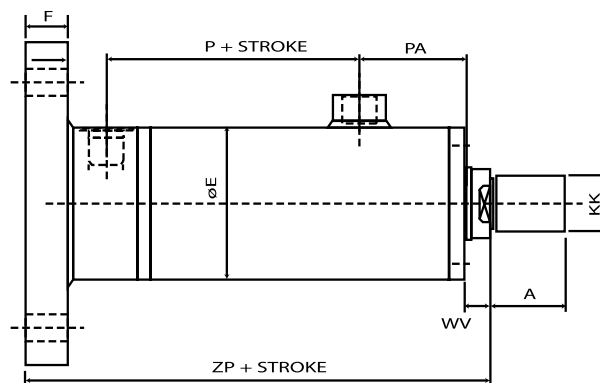
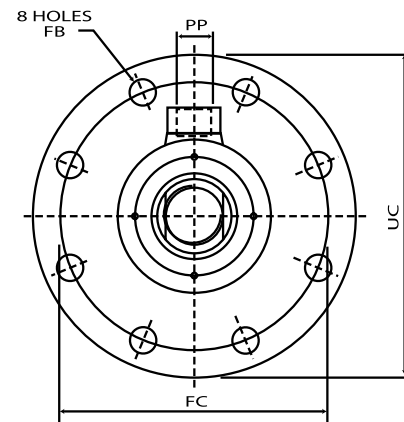

MF4 - CAP CIRCULAR FLANGE

Heavy Duty Roundline Cylinders cont.

HDR Foot Mount - FM1

BORE mm	MM ROD	KK THREAD	A	PP BSPP PORT	VD	ΦB	WC, W	WV	ΦE MAX	P (+str)	PA	ZB (+str)	FF (+str)	EE	GG	ΦNN	LL	MM	HH	JJ
40	22	M16 X 1.5	22	3/8	3	50	16	13	55	63.5	40	136	46	33	25	9	15	35	65	80
	28	M20 X 1.5	28																	
50	28	M20 X 1.5	28	3/8	4	60	18	14	65	68.5	45	147	51	39	32	11	20	40	88	108
	36	M27 X 2	36																	
63	36	M27 X 2	36	1/2	4	70	20	16	75	70	67	171	53	46	38	13.5	25	55	95	120
	45	M33 X 2	45																	
80	45	M33 X 2	45	1/2	4	85	22	18	95	78	77	193	63	53	43	18	30	65	120	150
	56	M42 X 2	56																	
100	56	M42 X 2	56	3/4	5	106	25	20	125	100	98	246	89	60	45	22	35	80	150	190
	70	M48 X 2	63																	
125	70	M48 X 2	63	1	5	132	28	23	150	116	138	288	103	73	55	26	40	95	185	230
	90	M64 X 3	85																	
160	90	M64 X 3	85	1 1/4	5	160	30	25	195	143	142	354	117	90	75	33	50	120	235	290
	110	M80 X 3	95																	
200	110	M80 X 3	95	1 1/2	5	200	35	30	245	160.5	139.5	374	111.5	105	85	39	60	147	290	360
	140	M100 X 3	112																	

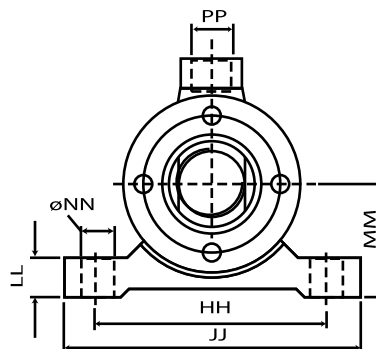
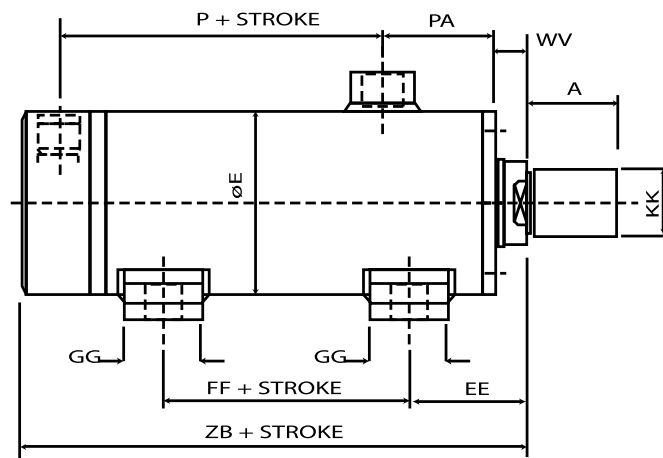

FM1 FOOT MOUNT



## Heavy Duty Roundline Cylinders cont.

### HDR Rod Clevis Mount

BORE mm	MM ROD	KK THREAD	A	QQ	L	MS	H	ΦC, EV, EZ, EY	XX	UU
40	22	M16 X 1.5	22	52	3	23.5	17	20	27	36
	28	M20 X 1.5	28	65	3	29	21	25	33	40
50	28	M20 X 1.5	28	65	3	29	21	25	33	40
	36	M27 X 2	36	80	3	35	27	32	43	66
63	36	M27 X 2	36	80	3	35	27	32	43	66
	45	M33 X 2	45	97	5	45.5	32	40	51	80
80	45	M33 X 2	45	97	5	45.5	32	40	51	80
	56	M42 X 2	56	120	5	54	40	50	64	96
100	56	M42 X 2	56	120	5	54	40	50	64	96
	70	M48 X 2	63	140	5	66	52	63	77	114
125	70	M48 X 2	63	140	5	66	52	63	77	114
	90	M64 X 3	85	180	6	84	66	80	95	148
160	90	M64 X 3	85	180	6	84	66	80	95	148
	110	M80 X 3	95	210	7	105	84	100	114	178
200	110	M80 X 3	95	210	7	105	84	100	114	178
	140	M100 X 3	112	260	14	131	102	125	147	200

SC SWIVEL CLEVIS

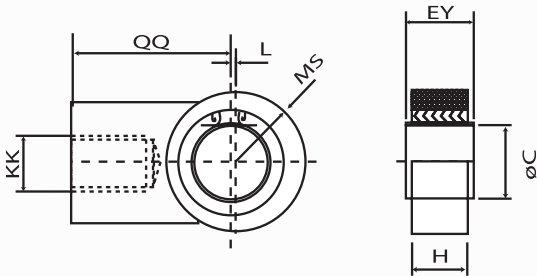

MC MALE CLEVIS

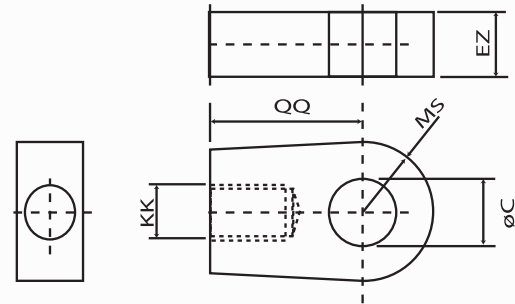

FC FEMALE CLEVIS & PIN

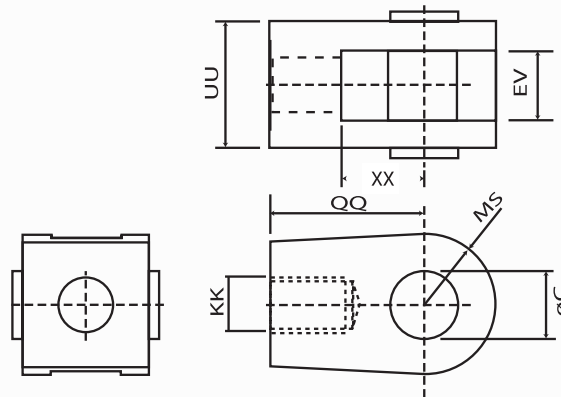

Specify in millimetres. If stroke is over 20 times cylinder bore, consult Berendsen Fluid Power.

## AM1 Mill Cylinders

Archer AM1 Series ISO mill type cylinders from Berendsen Fluid Power are the first choice for a well engineered, heavy duty hydraulic cylinder for a variety of industrial applications. Designed with the aid of computer by our Technical Services Group and manufactured in our custom built, cylinder manufacturing facility.

### Key Features:

- Manufactured to ISO 6022-1981 "Mounting Dimensions for 250 Bar Single Rod Cylinders" standards as specified by the Steel industry.
- Two additional non ISO standard bore sizes of 140 and 180mm have been added to supplement the range and bridge the gap between selected ISO sizes. We have also incorporated a non ISO standard foot mount option to maximize the options available to the user.
- The cylinder barrel is manufactured from high strength ST52 cold drawn seamless steel tube and hollow bar grade 750v. The bore is precision honed and polished to a micro finish.
- Both the gland and piston incorporate bronze impregnated Teflon wear rings to eliminate metal to metal contact and provide maximum bearing durability and strength.
- Both the gland and pistons use the latest technology in dynamic, self-adjusting seals, all designed to fit into ISO 5597-1990 housing dimensions.
- The piston rods are machined from high strength carbon alloy steel and hard chrome plated and ground to a micro-finish.
- The gland arrangement incorporates a heavy duty piston rod scraper to ISO 6195-1986 housing dimensions to prevent contamination from entering the cylinder.
- Cylinder bolts are high tensile grade 12.9 Unbrako socket head cap screws carefully tightened to the required torque for maximum strength and fatigue rating.
- We also offer a range of spherical bearing piston rod eyes to ISO 6982-1982
- Standard ports are BSP Parallel up to 200 bore and SAE code 62nflange connections for up to 500 bore. We are able to offer other port configurations on request.
- All cylinders come standard with fully integrated, cartridge type cushion arrangements for smooth cylinder deceleration which also include an air bleed/pressure test point at each end.

	Description	Code	Example
Series	Used in all AM1 Series	AM1	AM1 - 250 - 1430 - MF3 - MC - S
Bore	Specify in millimetres		
Stroke	Specify in millimetres. If stroke is over 20 times cylinder bore, consult Berendsen Fluid Power.		
Mounting Type	Swivel Clevis	MP5	
	Head Flange	MF3	
	Cap Flange	MF4	
	Trunnion	MT4	
	Foot	MFM	
Port Options	Swivel Clevis	SC	
	Male Clevis	MC	
	Female Clevis	FC	
	(Omit if not required)		
Special Features	Specify with order or provide drawing	S	
	(Omit if not required)		

- **Standard operating limits**  
 Fluid: Hydraulic mineral oil  
 Viscosity: 2.8 to 380cST  
 Oil Temperature: -30° to 90°  
 Operating Speed: 50 mm/sec. maximum
- **Non-standard cylinders**  
 Any cylinder configurations outside of those detailed in this catalogue are subject to individual design and quotation.



## AM1 Mill Cylinders cont.

### AM1 Swivel Clevis - MP5

BORE mm	MM ROD	KK THREAD	A	F PORTS	ΦE	Y	P (+stk)	WF	VE	XC	LT	L	MS	ΦCX	EX	H
50	36	M27-2.OP	36	1/2" BSPP	108	95	125	47	29	305	61	3	35	32	32	27
63	45	M33-2.OP	45	3/4" BSPP	122	105	140	53	32	348	74	3	45.5	40	40	32
80	56	M42-2.OP	56	3/4" BSPP	142	122	152	60	36	395	91	5	54	50	50	40
100	70	M48-2.OP	63	1" BSPP	172	135	170	68	41	442	102	5	66	63	63	52
125	90	M64-3.OP	85	1" BSPP	215	165	190	76	45	520	125	6	84	80	80	66
140	100	M72-3.OP	90	1 1/4" BSPP	255	176	209	80	48	580	150	8.5	92.5	90	90	72
160	110	M80-3.OP	95	1 1/4" BSPP	270	185	235	85	50	617	152	7	105	100	100	84
180	125	M90-3.OP	105	1 1/4" BSPP	315	205	250	95	55	690	185	11.5	117.5	110	110	88
200	140	M100-3.OP	112	1 1/2" BSPP	330	225	270	101	61	756	211	14	131	125	125	102
250	180	M125-4.OP	125	1 1/2" SAE-62	412	255	330	113	71	903	255	15	163	160	160	130
320	220	M160-4.OP	160	2" SAE-62	500	295	380	136	88	1080	322	21	209	200	200	162
400	280	M200-4.OP	20	2" SAE-62	620	275	420	163	110	1075	310	27	290	250	250	192
500	360	M250-6.OP	250	2 1/2" SAE-62	750	335	480	195	135	1275	365	25	350	320	320	260

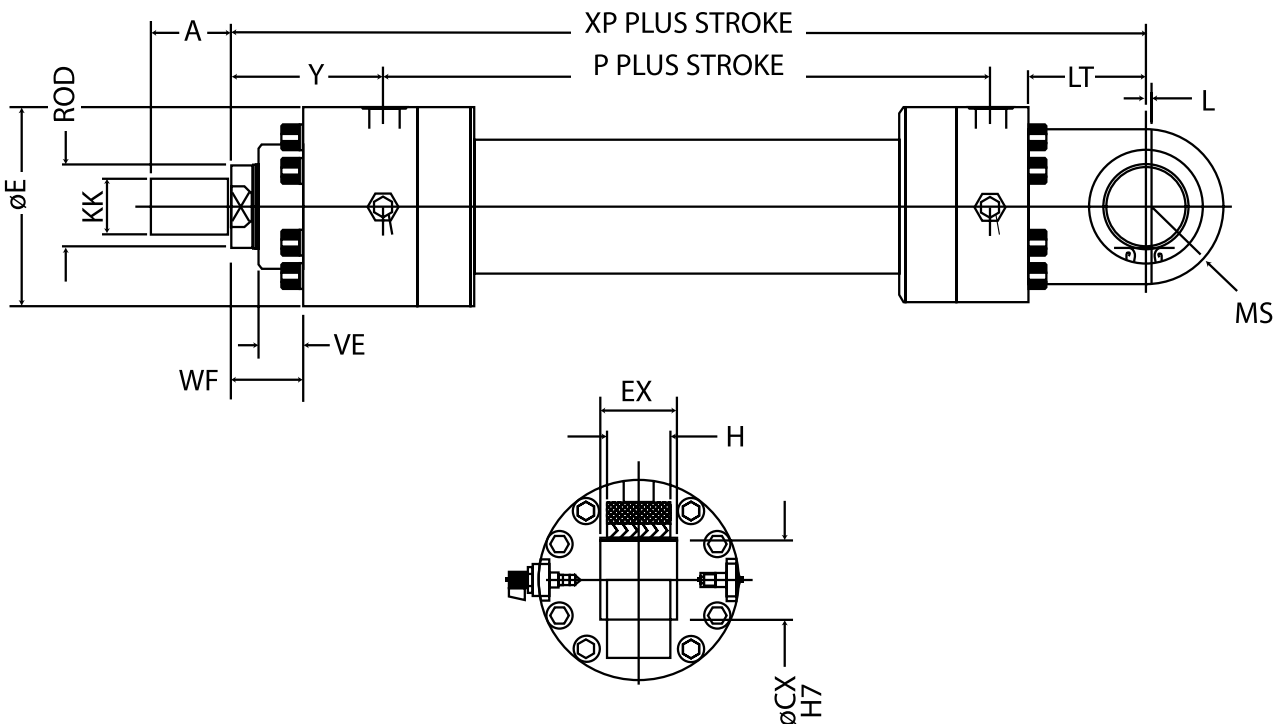

AM1 Mill Cylinders cont.

AM1 Trunnion Mount - MT4

BORE mm	MM ROD	KK THREAD	A	F PORTS	ΦE	Y	P	WF	VE	ZB	XV	ΦTD	TM	TL	U	V
50	36	M27-2.OP	36	1/2" BSPP	108	95	125	47	29	244	157	32	112	25	40	0.8
63	45	M33-2.OP	45	3/4" BSPP	122	105	140	53	32	274	175	40	125	32	50	1
80	56	M42-2.OP	56	3/4" BSPP	142	122	152	60	36	304	198	50	150	40	65	1
100	70	M48-2.OP	63	1" BSPP	172	135	170	68	41	340	220	63	180	50	80	1.2
125	90	M64-3.OP	85	1" BSPP	215	165	190	76	45	395	260	80	224	63	100	1.2
140	100	M72-3.OP	90	1 1/4" BSPP	255	176	209	80	48	430	285	90	265	70	110	1.5
160	110	M80-3.OP	95	1 1/4" BSPP	270	185	235	85	50	465	305	100	280	8	120	1.5
180	125	M90-3.OP	105	1 1/4" BSPP	315	205	250	95	55	505	330	110	320	90	140	1.5
200	140	M100-3.OP	112	1 1/2" BSPP	330	225	270	101	61	545	360	125	335	100	155	1.5
250	180	M125-4.OP	125	1 1/2" SAE-62	412	255	330	113	71	648	420	160	425	125	200	1.5
320	220	M160-4.OP	160	2" SAE-62	500	295	380	136	88	758	485	200	530	160	250	2
400	280	M200-4.OP	20	2" SAE-62	620	275	420	163	110	765	485	250	630	200	320	2
500	360	M250-6.OP	250	2 1/2" SAE-62	750	335	480	195	135	910	575	320	760	250	400	2

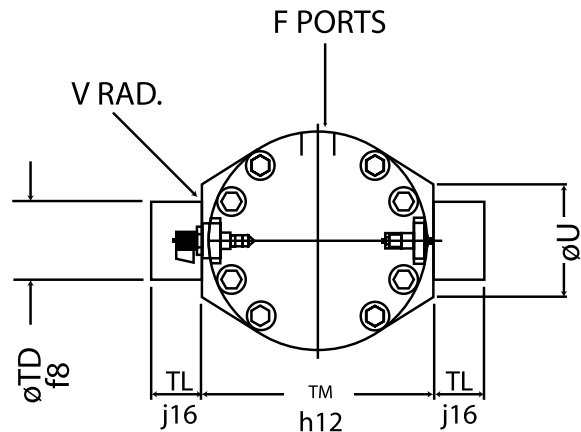
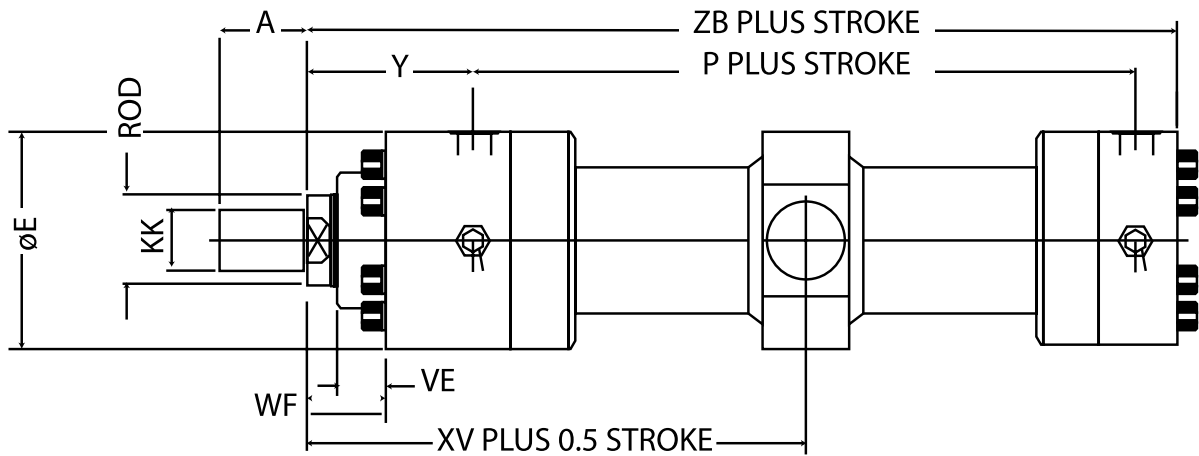



## AM1 Mill Cylinders cont.

### AM1 Cap Flange - MF4

BORE mm	MM ROD	KK THREAD	A	F PORTS	ΦE	Y	P	WF	VE	ZP	ΦUC	ΦBA	X	AA	ΦFB	DD°
50	36	M27-2.OP	36	1/2" BSPP	108	95	125	47	29	265	155	63	25	8	13.5	22.5
63	45	M33-2.OP	45	3/4" BSPP	122	105	140	53	32	298	175	75	28	8	13.5	22.5
80	56	M42-2.OP	56	3/4" BSPP	142	122	152	60	36	332	210	90	32	8	17.5	22.5
100	70	M48-2.OP	63	1" BSPP	172	135	170	68	41	371	250	110	36	8	22	22.5
125	90	M64-3.OP	85	1" BSPP	215	165	190	76	45	430	290	132	40	8	22	22.5
140	100	M72-3.OP	90	1 1/4" BSPP	255	176	209	80	48	465	340	145	43	8	26	22.5
160	110	M80-3.OP	95	1 1/4" BSPP	270	185	235	85	50	505	360	160	45	8	26	22.5
180	125	M90-3.OP	105	1 1/4" BSPP	315	205	250	95	55	550	420	185	50	8	33	22.5
200	140	M100-3.OP	112	1 1/2" BSPP	330	225	270	101	61	596	440	200	56	8	33	22.5
250	180	M125-4.OP	125	1 1/2" SAE-62	412	255	330	113	71	703	540	250	63	8	39	22.5
320	220	M160-4.OP	160	2" SAE-62	500	295	380	136	88	830	675	320	80	8	45	22.5
400	280	M200-4.OP	20	2" SAE-62	620	275	420	163	110	855	800	400	100	12	45	-
500	360	M250-6.OP	250	2 1/2" SAE-62	750	335	480	195	135	1025	950	500	125	12	52	-

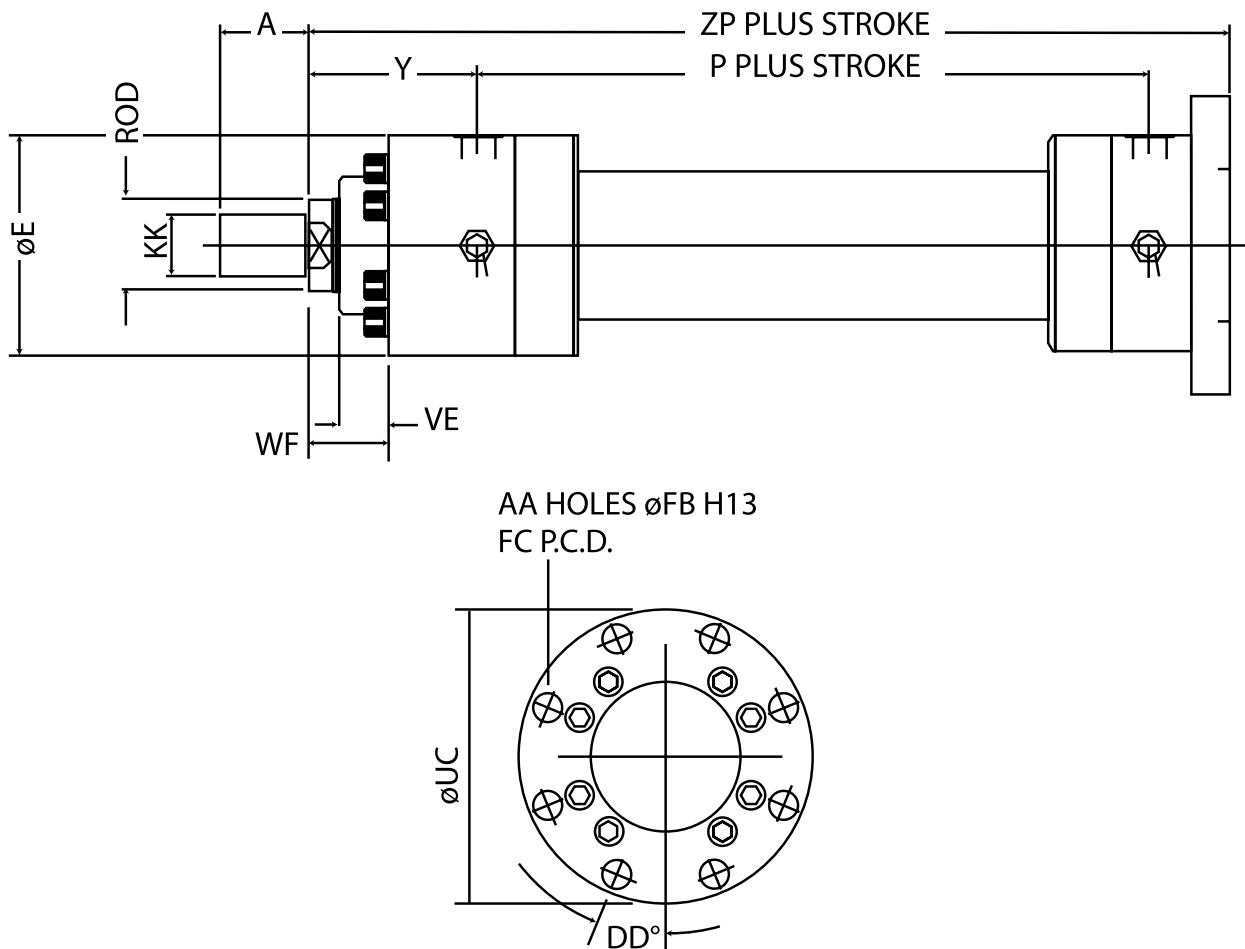

AM1 Mill Cylinders cont.

AM1 Head Flange - MF3

BORE mm	MM ROD	KK THREAD	A	F PORTS	ΦE	Y	P	WF	VE	ZB	VD	ΦUC	ΦBA	AA	ΦFB	FC	DD°
50	36	M27-2.OP	36	1/2" BSPP	108	95	125	47	29	244	4	155	63	8	13.5	132	22.5
63	45	M33-2.OP	45	3/4" BSPP	122	105	140	53	32	274	4	175	75	8	13.5	150	22.5
80	56	M42-2.OP	56	3/4" BSPP	142	122	152	60	36	304	4	210	90	8	17.5	180	22.5
100	70	M48-2.OP	63	1" BSPP	172	135	170	68	41	340	5	250	110	8	22	212	22.5
125	90	M64-3.OP	85	1" BSPP	215	165	190	76	45	395	5	290	132	8	22	250	22.5
140	100	M72-3.OP	90	1 1/4" BSPP	255	176	209	80	48	430	5	340	145	8	26	300	22.5
160	110	M80-3.OP	95	1 1/4" BSPP	270	185	235	85	50	465	5	360	160	8	26	315	22.5
180	125	M90-3.OP	105	1 1/4" BSPP	315	205	250	95	55	505	5	420	185	8	33	365	22.5
200	140	M100-3.OP	112	1 1/2" BSPP	330	225	270	101	61	545	5	440	200	8	33	385	22.5
250	180	M125-4.OP	125	1 1/2" SAE-62	412	255	330	113	71	648	8	540	250	8	39	475	22.5
320	220	M160-4.OP	160	2" SAE-62	500	295	380	136	88	758	8	675	320	8	45	600	22.5
400	280	M200-4.OP	20	2" SAE-62	620	275	420	163	110	765	10	800	400	12	45	720	-
500	360	M250-6.OP	250	2 1/2" SAE-62	750	335	480	195	135	910	10	950	500	12	52	840	-

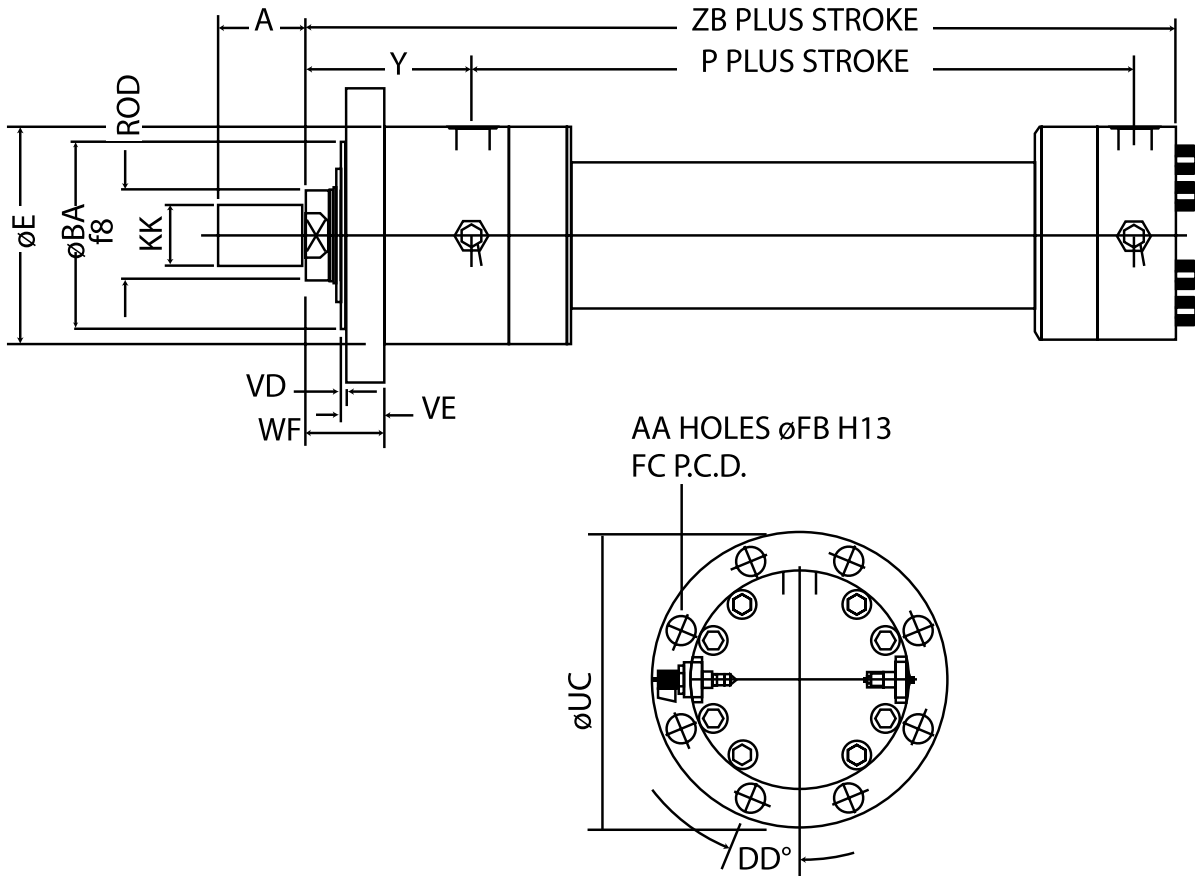



## AM1 Mill Cylinders cont.

### AM1 Foot Mount - MFM

BORE mm	MM ROD	KK THREAD	A	F PORTS	ΦE	Y	P	WF	VE	ZB	EE	FF	GG	HH	JJ	MM	LL	ΦNN
50	36	M27-2.OP	36	1/2" BSPP	108	95	125	47	29	244	134	47	38	135	160	60	32	11
63	45	M33-2.OP	45	3/4" BSPP	122	105	140	53	32	274	151	47	43	155	185	68	37	13.5
80	56	M42-2.OP	56	3/4" BSPP	142	122	152	60	36	304	170	55	45	185	225	80	42	17.5
100	70	M48-2.OP	63	1" BSPP	172	135	170	68	41	340	192	55	55	220	265	95	52	22
125	90	M64-3.OP	85	1" BSPP	215	165	190	76	45	395	230	60	60	270	325	115	62	26
140	100	M72-3.OP	90	1 1/4" BSPP	255	176	209	80	48	430	255	52	75	325	390	135	77	30
160	110	M80-3.OP	95	1 1/4" BSPP	270	185	235	85	50	465	268	70	75	340	405	145	77	33
180	125	M90-3.OP	105	1 1/4" BSPP	315	205	250	95	55	505	288	85	85	390	465	165	87	40
200	140	M100-3.OP	112	1 1/2" BSPP	330	225	270	101	61	545	315	90	90	405	480	170	87	40
250	180	M125-4.OP	125	1 1/2" SAE-62	412	255	330	113	71	648	360	120	100	520	620	215	112	52
320	220	M160-4.OP	160	2" SAE-62	500	295	380	136	88	758	425	120	120	620	740	260	152	62
400	280	M200-4.OP	20	2" SAE-62	620	275	420	163	110	765	440	90	190	780	940	320	202	82
500	360	M250-6.OP	250	2 1/2" SAE-62	750	335	480	195	135	910	545	60	250	950	1150	385	252	102

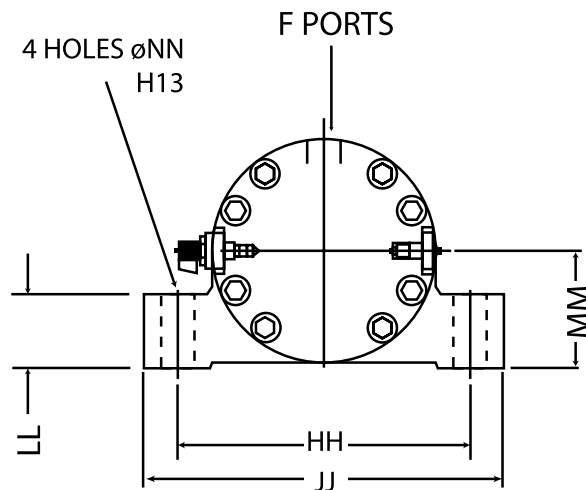
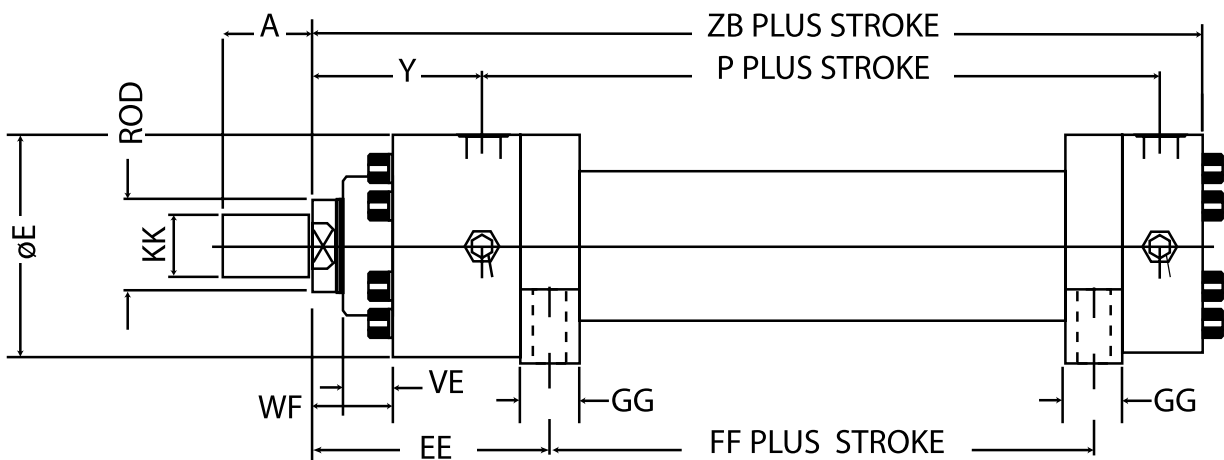

AM1 Mill Cylinders cont.

AM1 Rod Clevis Mount

BORE mm	MM ROD	KK THREAD	A	QQ	L	MS	H	ΦC, EV, EZ, EY	XX	UU
40	22	M16 X 1.5	22	52	3	23.5	17	20	27	36
	28	M20 X 1.5	28	65	3	29	21	25	33	40
50	28	M20 X 1.5	28	65	3	29	21	25	33	40
	36	M27 X 2	36	80	3	35	27	32	43	66
63	36	M27 X 2	36	80	3	35	27	32	43	66
	45	M33 X 2	45	97	5	45.5	32	40	51	80
80	45	M33 X 2	45	97	5	45.5	32	40	51	80
	56	M42 X 2	56	120	5	54	40	50	64	96
100	56	M42 X 2	56	120	5	54	40	50	64	96
	70	M48 X 2	63	140	5	66	52	63	77	114
120	70	M48 X 2	63	140	5	66	52	63	77	114
	90	M64 X 3	85	180	6	84	66	80	95	148
160	90	M64 X 3	85	180	6	84	66	80	95	148
	110	M80 X 3	95	210	7	105	84	100	114	178
200	110	M80 X 3	95	210	7	105	84	100	114	178
	140	M100 X 3	112	260	14	131	102	125	147	200

SC SWIVEL CLEVIS

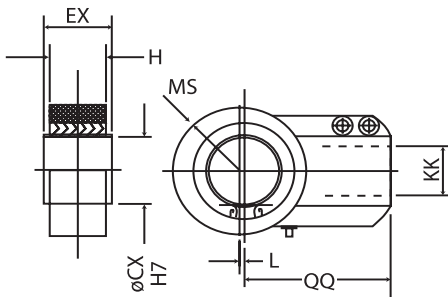

MC MALE CLEVIS

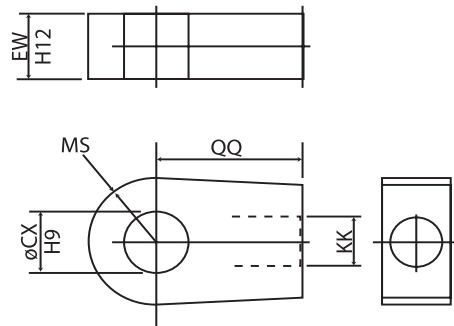

FC FEMALE CLEVIS & PIN

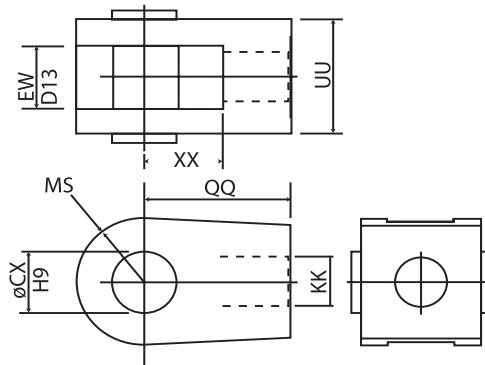



## Custom Design Cylinders

Berendsen Fluid Power's Custom Designed and Manufactured cylinders are the first choice for a well engineered and manufactured cylinder for the diverse mobile and industrial applications. Designed with the aid of computer generated calculations and drawings, the cylinders are manufactured in our dedicated manufacturing facility in Newcastle.

Our custom cylinders are designed with reference to the application and the user's specification. We are able to offer a cylinder fully conforming to the standard upon request.

We have included some samples of our previous work for your reference.

### Example 1

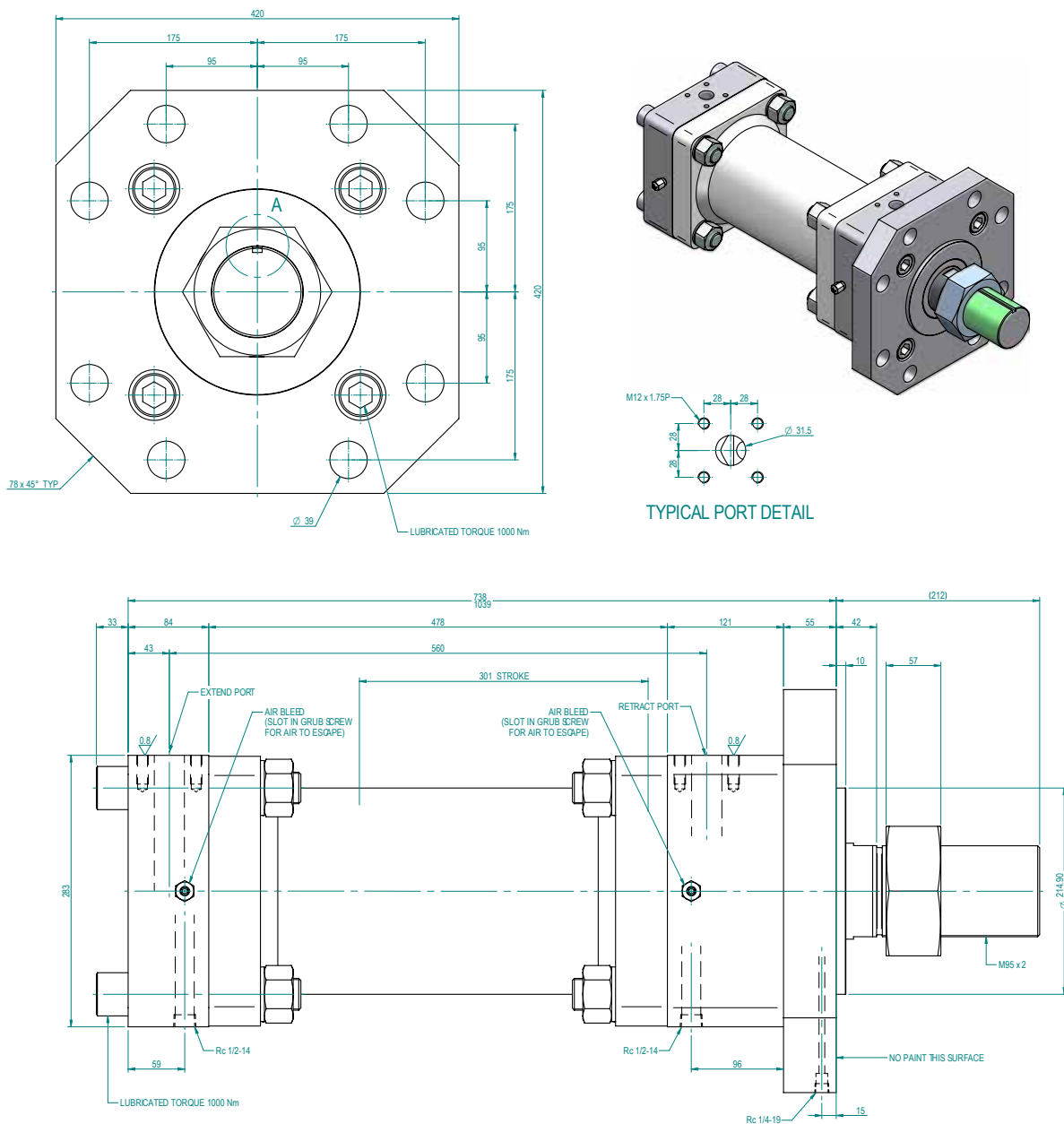

Custom Design Cylinders cont.

Example 2

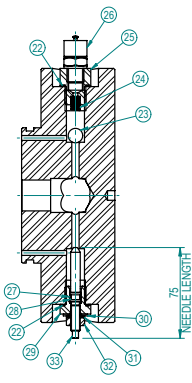
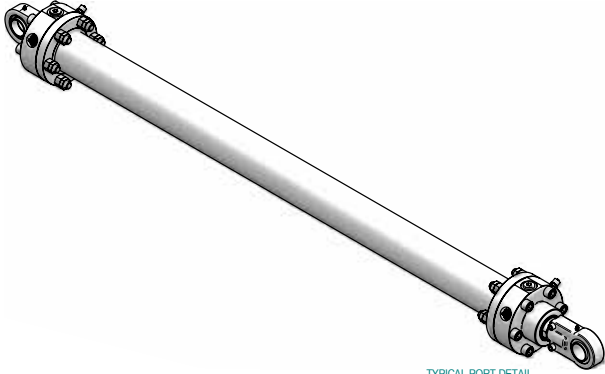

SECTION B-B  
TYP SECTION THROUGH  
CUSHION VALVES

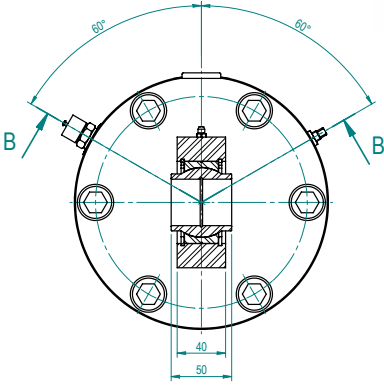

VIEW C  
SECTION THROUGH CLEVIS  
TYPICAL EACH END

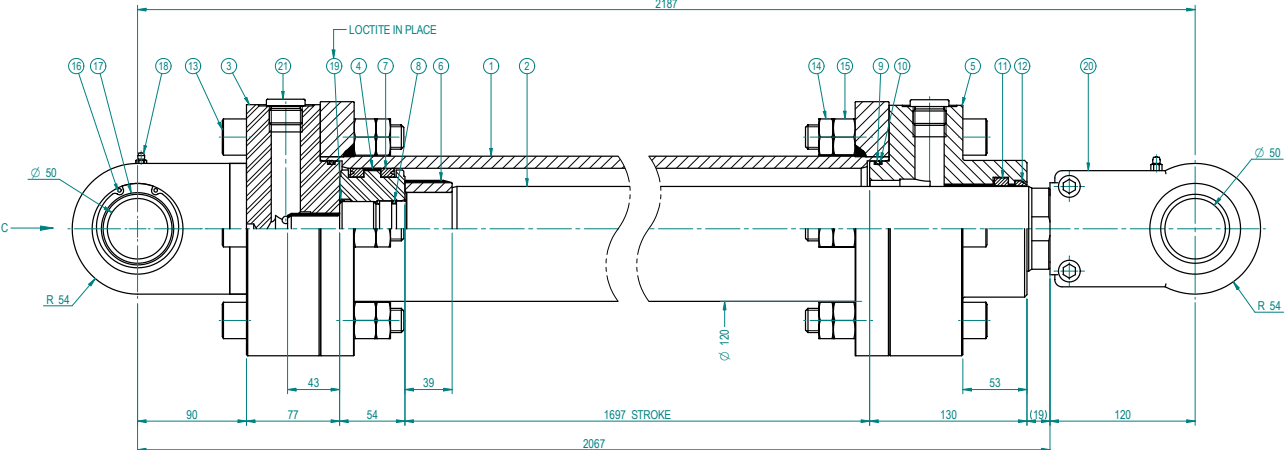
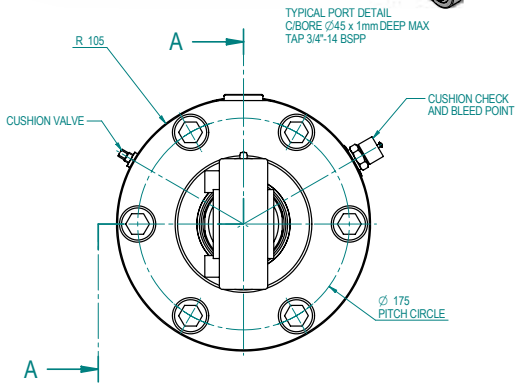

SECTION A-A



## Custom Design Cylinders cont.

### Example 3

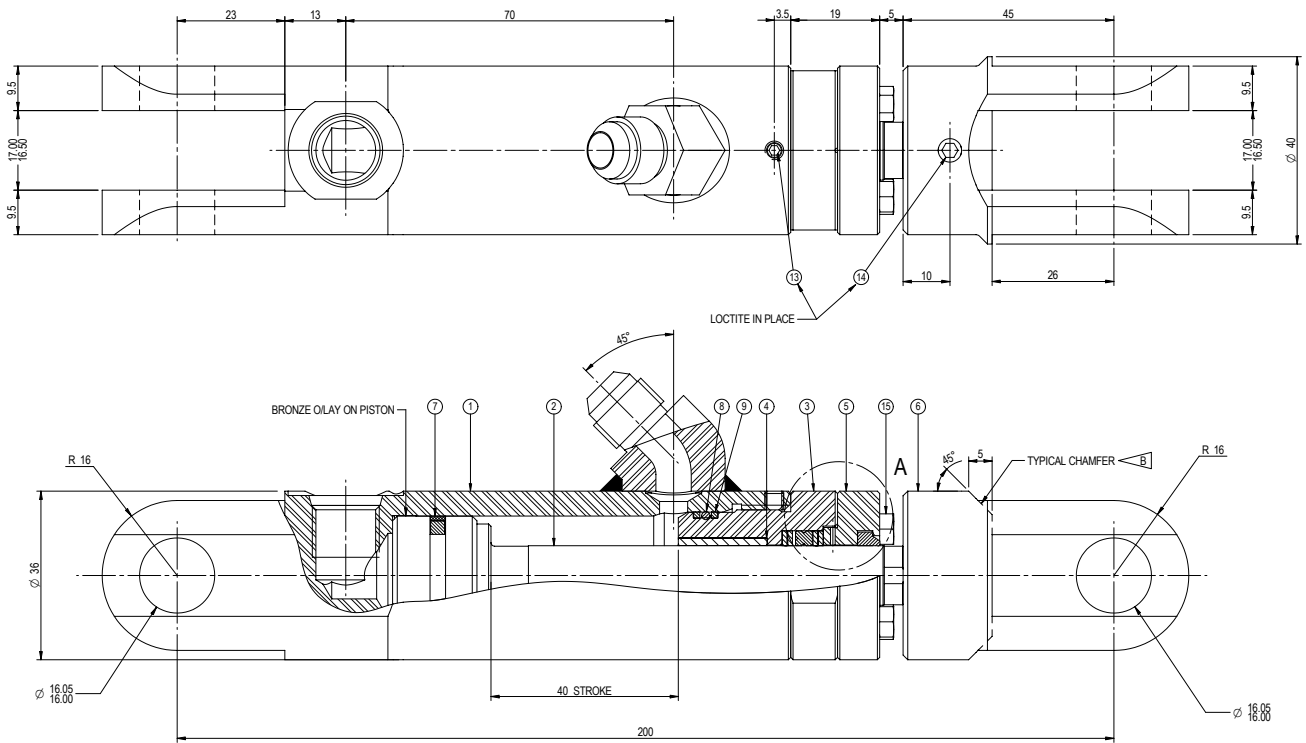
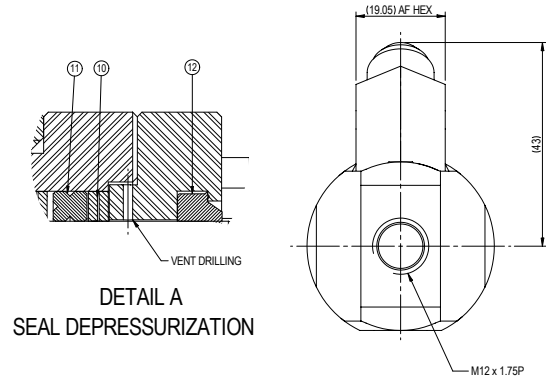
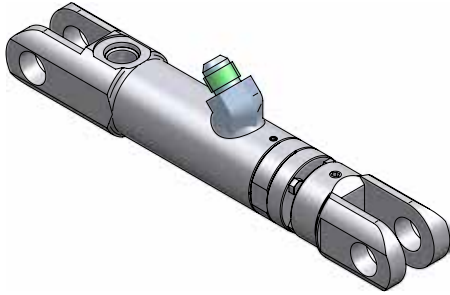

Custom Design Cylinders cont.

Example 4

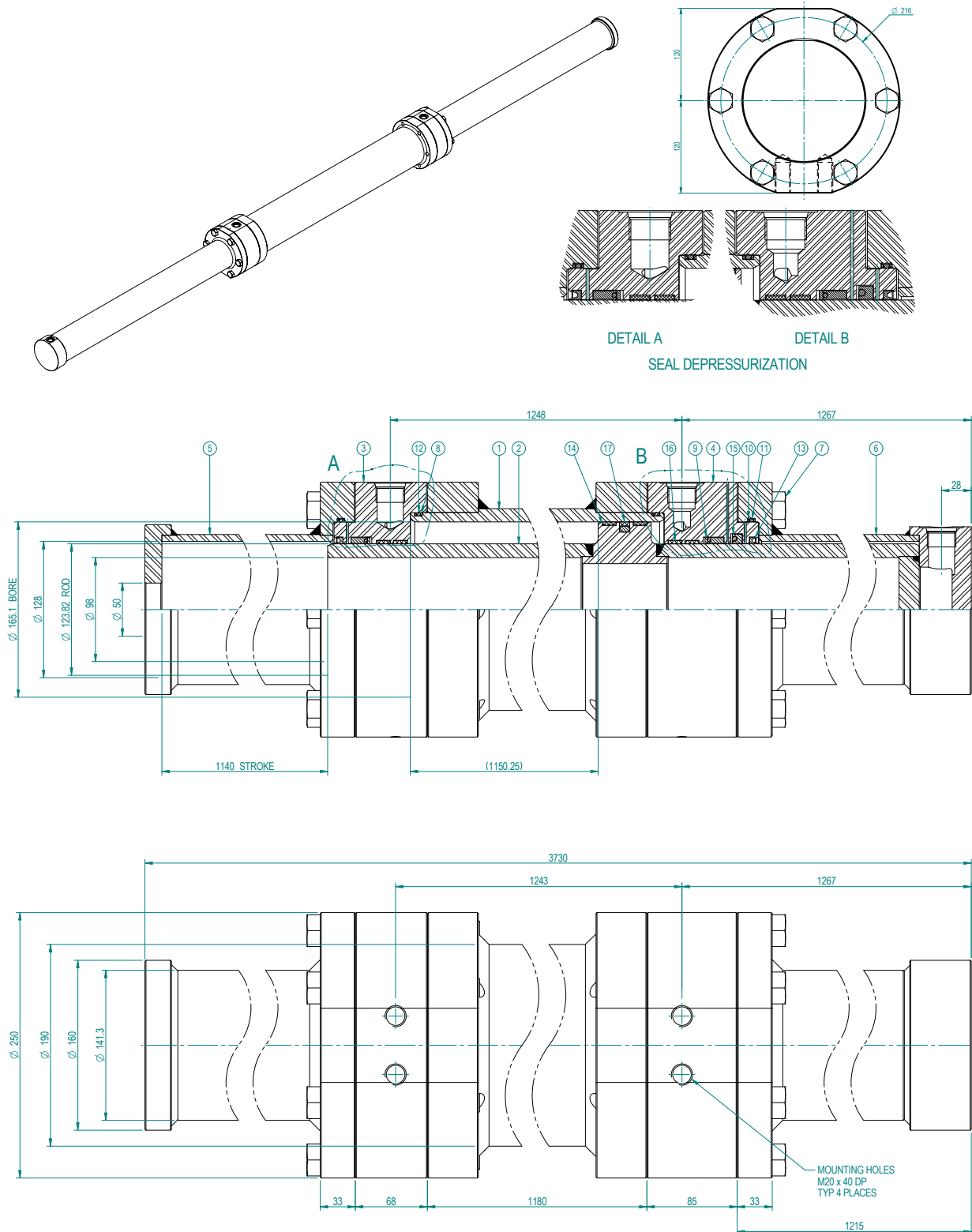



## Telescopic Cylinders

Berendsen Fluid Power's Custom Designed and Manufactured Telescopic cylinders are the first choice for a well engineered and manufactured cylinder for the diverse mobile and industrial applications. Designed with the aid of computer generated calculations and drawings, the cylinders are manufactured in our dedicated manufacturing facility in Newcastle.

Designed with reference to the application and the user's specification. We are able to offer a cylinder fully conforming to the standard upon request.

We have included samples of our previous work for your reference.

### Example 1

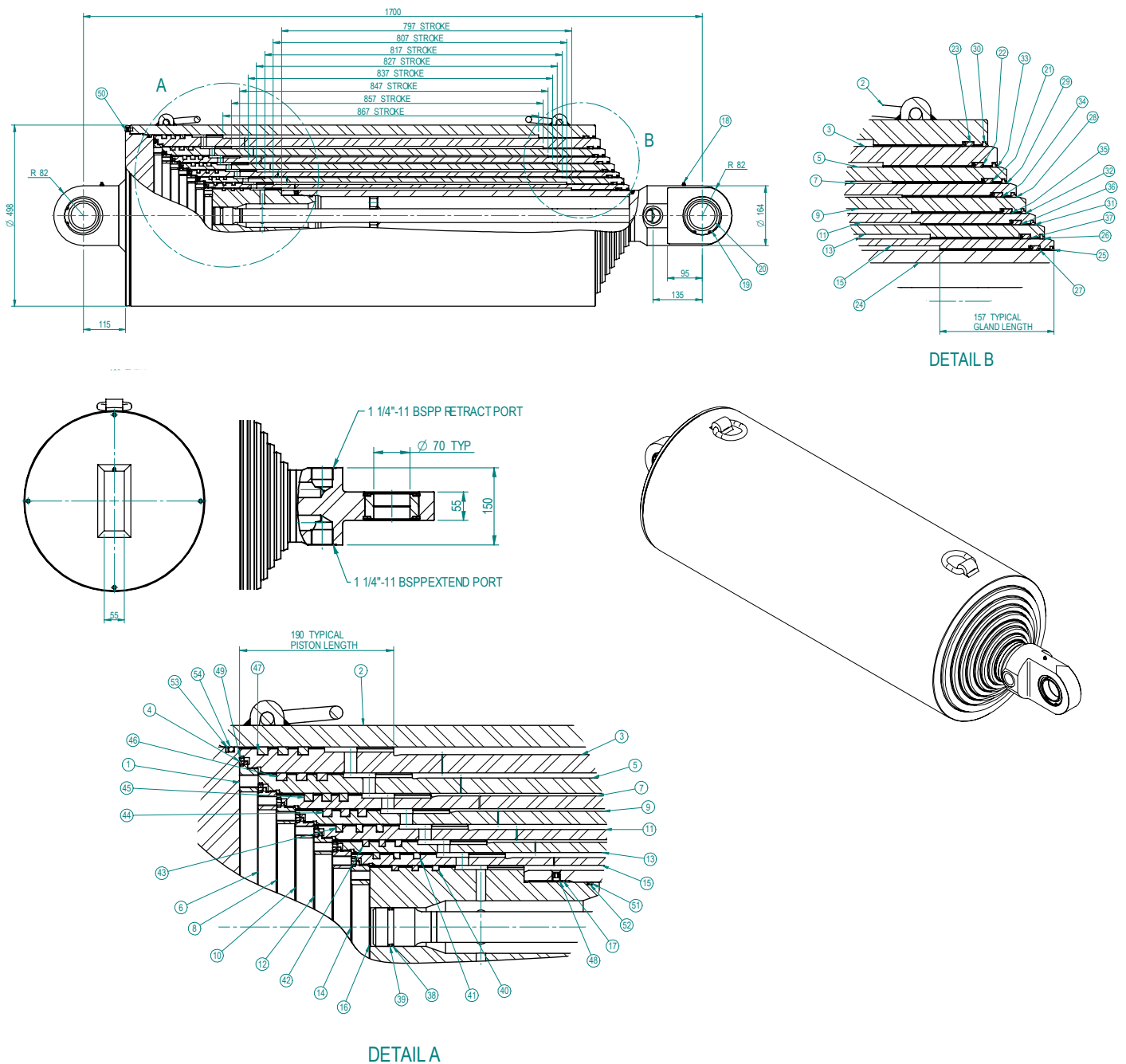

Telescopic Cylinders cont.

Example 2

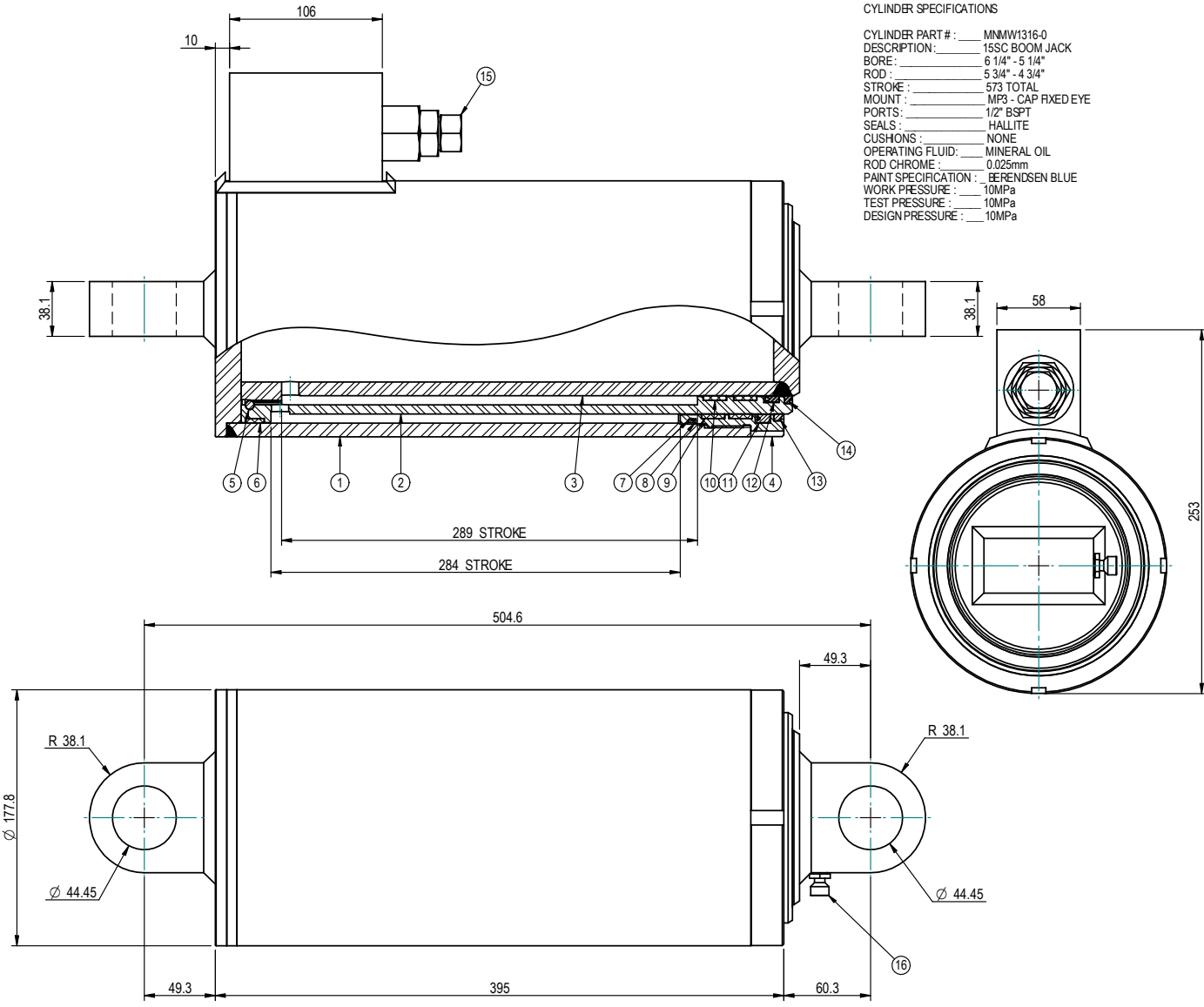



## Technical Information

### Useful Hydraulic Formulas

Theoretical Thrust (Cylinders)	N=	Effective area (sq.cm) x pressure (bar) x 10
	Lb=	Effective area (sq.in) x pressure (psi)
Hydraulic Power	kW=	$\frac{\text{Flow rate (L/min)} \times \text{pressure (bar)}}{600}$
	hp=	$\frac{\text{Flow rate (gpm)} \times \text{pressure (psi)}}{1714}$
Geometric Flow Rate (Cylinders)	L/min=	$\frac{\text{Effective area (sq.cm)} \times \text{piston speed (m/min)}}{10}$
	gpm=	$\frac{\text{Effective area (sq.cm)} \times \text{piston speed (in/min)}}{231}$
Velocity of Fluid in Pipe	m/sec=	$\frac{\text{Flow rate (L/min)} \times 21.22}{D \times D}$ (D: inside diameter of pipe in mm)
	ft/sec=	$\frac{\text{Flow rate (gpm)} \times 0.408}{D \times D}$ (D: inside diameter of pipe in mm)

### Conversion Factors

To convert	→	into	-----	Multiply by the factor below
Into	←	into	-----	Divide by the factor below

Unit (Symbol)	Unit (Symbol)	Factor
Inches (in)	Millimetres (mm)	25.4
Inches (in)	Centimetres (cm)	2.54
Inches (in)	Metres (m)	0.0254
Feet (ft)	Metres (m)	0.3084
Square Inches (sq.in)	Square Centimetres (sq.cm)	6.4516
Cubic Inches (cu.in)	Cubic Centimetres (cu.cm)	16.3871
Cubic Inches (cu.in)	Litres (L)	0.0163866
Pounds (lb) – mass	Kilograms (kg)	0.4536
Pounds per square inch (psi)	Bar (bar)	0.06894
Megapascals (MPa)	Bar (bar)	10
Horsepower (hp)	Kilowatts (kW)	0.7457
US Gallons (gal-US)	Litres (lit)	3.78531
Newtons/sq.centimetre (N/sq.cm)	Bar (bar)	0.1

**Technical Information cont.**

**Theoretical Push and Pull Forces**

**PUSH FORCE AND DISPLACEMENT**

CYLINDER BORE		PISTON ROD DIAMETER		PISTON AREA		CYLINDER PUSH STROKE FORCE AT VARIOUS PRESSURES										DISPLACEMENT PER cm/in OF STROKE	
						35 bar (500 psi)		69 bar (1000 psi)		103 bar (1500 psi)		138 bar (2000 psi)		207 bar (3000 psi)		cm	in
mm	in	mm	in	sq.cm	sq.in	kN	kgf	kN	kgf	kN	kgf	kN	kgf	kN	kgf	litres	Usgpm
50.8	2.0	25.40	1.0	20.27	3.14	6.98	712	13.97	1425	20.95	2136	27.93	2848	41.9	4273	0.02027	0.0136
63.5	2.5	34.93	1.375	31.67	4.91	10.92	1114	21.84	2227	32.76	3341	43.68	4454	65.62	6691	0.0317	0.0213
76.2	3.0	34.93	1.375	45.62	7.07	15.74	1605	31.48	3210	47.17	4810	62.91	6415	94.39	9625	0.0456	0.0301
88.9	3.5	44.45	1.75	62.1	9.63	21.42	2184	42.85	4369	64.21	6548	85.64	8733	128.48	13101	0.0621	0.0345
101.6	4.0	50.80	2.0	81.07	12.57	27.96	2851	55.91	5701	83.87	8552	111.83	11403	167.74	17105	0.0817	0.0550
114.3	4.5	50.80	2.0	102.64	15.91	35.41	3611	70.82	7222	106.13	10822	141.54	14433	212.36	21655	0.1026	0.0689
127.0	5.0	50.80	2.0	126.68	19.64	43.68	4454	87.36	8908	131.04	13362	174.73	17818	262.09	26726	0.1267	0.0850

**PULL FORCE AND DISPLACEMENT**

CYLINDER BORE		PISTON ROD DIAMETER		ANNULUS AREA		CYLINDER PUSH STROKE FORCE AT VARIOUS PRESSURES										DISPLACEMENT PER cm/in OF STROKE	
						35 bar (500 psi)		69 bar (1000 psi)		103 bar (1500 psi)		138 bar (2000 psi)		207 bar (3000 psi)		cm	in
mm	in	mm	in	sq.cm	sq.in	kN	kgf	kN	kgf	kN	kgf	kN	kgf	kN	kgf	litres	Usgpm
50.8	2.0	25.40	1.0	15.2	2.36	2.25	229	10.50	1071	15.75	1606	21.00	2141	31.49	3211	0.0125	0.01022
63.5	2.5	34.93	1.375	22.09	3.43	7.62	777	15.24	1554	22.84	2329	30.46	3106	45.70	4660	0.02209	0.01484
76.2	3.0	34.93	1.375	36.03	5.59	12.43	1268	24.83	2532	37.25	3798	49.67	5065	74.50	7597	0.036	0.0095
88.9	3.5	44.45	1.75	46.58	7.22	16.07	1639	32.10	3273	48.14	4909	64.19	6546	96.30	9820	0.0466	0.0123
101.6	4.0	50.80	2.0	60.8	9.43	20.96	2137	41.92	4275	62.88	6412	83.84	8549	125.80	12828	0.0608	0.1610
114.3	4.5	50.80	2.0	82.34	12.76	28.38	2894	56.77	5789	85.15	8683	113.50	11574	170.30	17366	0.0823	0.218
127.0	5.0	50.80	2.0	106.41	16.49	36.68	3740	73.35	7480	110.03	11220	146.71	14960	220.05	22439	0.10641	0.7139

Note The push and pull forces listed are only theoretical.

When selecting a cylinder from this catalogue, it is imperative that you analyse all aspects of your application, especially pressure reductions applicable to certain bore diameters and stroke length.







**BERENDSEN**  
FLUID POWER

1800 660 249 | [info@berendsen.com.au](mailto:info@berendsen.com.au)  
[www.berendsen.com.au](http://www.berendsen.com.au)

Berendsen Fluid Power Pty Ltd - ABN 29 058 390 382